

# OAK FLOORING

(THIRD EDITION)

---

COMMERCIAL STANDARD CS56-49

[Supersedes CS56-41]

Effective Date for New Production From February 25, 1949



A RECORDED VOLUNTARY STANDARD  
OF THE TRADE

UNITED STATES DEPARTMENT OF COMMERCE

CHARLES SAWYER, Secretary

---

For sale by the Superintendent of Documents, U. S. Government Printing Office  
Washington 25, D. C. - Price 10 cents

# COMMODITY STANDARDS

Simplified Practice Recommendations and Commercial Standards are developed by manufacturers, distributors, and users in cooperation with the Commodity Standards Division of the National Bureau of Standards. The purpose of Simplified Practice Recommendations is to eliminate avoidable waste through the establishment of standards of practice for stock sizes and varieties of specific commodities that currently are in general production and demand. The purpose of Commercial Standards is to establish standard methods of testing, rating, certification, and labeling of commodities, and to provide uniform bases for fair competition.

The adoption and use of a Simplified Practice Recommendation or Commercial Standard is voluntary. However, when reference to a Commercial Standard is made in contracts, labels, invoices, or advertising literature, the provisions of the standard are enforceable through usual legal channels as a part of the sales contract.

A Simplified Practice Recommendation or Commercial Standard originates with the proponent industry. The sponsors may be manufacturers, distributors, or users of the specific product. One of these three elements of industry submits to the Commodity Standards Division the necessary data to be used as the basis for developing a standard of practice. The Division, by means of assembled conferences or letter referenda, or both, assists the sponsor group in arriving at a tentative standard of practice and thereafter refers it to the other elements of the same industry for approval or for constructive criticism that will be helpful in making any necessary adjustments. The regular procedure of the Division assures continuous servicing of each effective Simplified Practice Recommendation and Commercial Standard, through review and revision, whenever, in the opinion of the industry, changing conditions warrant such action. Simplified Practice Recommendations and Commercial Standards are printed and made available by the Department of Commerce through the Government Printing Office.

---

## COMMERCIAL STANDARD FOR OAK FLOORING

On December 12, 1935, the National Oak Flooring Manufacturers' Association requested that its grading rules be submitted to manufacturers, distributors, and users for approval as a commercial standard for white- and red-oak flooring. These grading rules were accepted by the trade and approved for promulgation as Commercial Standard CS56-36, Oak Flooring. This standard was revised in 1941.

A second revision, submitted by the National Oak Flooring Manufacturers' Association and approved by the standing committee, was circulated on September 30, 1948, to the trade for written acceptance. Those concerned have since accepted and approved the revised standard as shown herein.

*Project Manager:* J. W. MEDLEY, Commodity Standards Division,  
National Bureau of Standards.

*Technical Adviser:* V. B. PHELAN, Building Technology Division,  
National Bureau of Standards.

# COMMERCIAL STANDARD CS56-49

for

## OAK FLOORING

(THIRD EDITION)

### PURPOSE

1. This standard for white-oak and red-oak flooring is a basis for common understanding between manufacturers, distributors, and users of this product. By its general acceptance, use, and certification by labels, it is hoped to increase interest in the manufacture, sale, and use of oak flooring manufactured to standard grades, to the mutual advantage of all concerned.

2. The service and satisfaction afforded by oak flooring, and, consequently, the success of the industry, depend on the use of universally recognized grades, and, therefore, the following commercial standard is provided for guidance in the manufacture, sale, and use of this product.

### SCOPE

3. This standard provides minimum specifications for three grades of quarter-sawed and four grades of plain-sawed white-oak and red-oak flooring. It covers standard dimensions for length, width, and thickness of tongued-and-grooved and square-edged strip flooring. It also covers defects, bundling, inspection, and a method of certifying compliance with the standard.

### GENERAL REQUIREMENTS

4. All commercial standard oak flooring, except square-edged strips, shall be tongued, grooved, and end-matched in accordance with the standard dimensions shown in figures 1, 2, and 3. It shall be well manufactured and properly kiln-dried, and it shall comply with the specifications given herein.

### DETAIL REQUIREMENTS

#### QUARTER-SAWED GRADES

5. *Clear.*—The face shall be practically free of defects, except that  $\frac{3}{8}$  inch of bright sapwood will be permitted. The question of color shall not be considered.<sup>1</sup> Bundles shall be 2 feet and up in length, not to exceed 25 percent under 4 feet. Average length, 4½ feet.

<sup>1</sup> This applies to standard grades. Flooring separated for color can be obtained as a special by adding color requirements to the specifications.

6. *Sap clear*.—The face shall be practically free of defects, but unlimited bright sapwood will be permitted. The question of color shall not be considered.<sup>2</sup> Bundles shall be 2 feet and up in length, not to exceed 25 percent under 4 feet. Average length, 4½ feet.

7. *Select*.—The face may contain sapwood, and will admit pinworm holes, streaks, slight imperfections in working, or a small tight knot, not to exceed one to every 3 feet in length. Bundles shall be 2 feet and up in length. Average length, 4 feet.

#### PLAIN-SAWED GRADES

8. *Clear*.—The face shall be practically free of defects, except that ⅜ inch of bright sapwood will be permitted. The question of color shall not be considered.<sup>3</sup> Bundles shall be 2 feet and up in length, not to exceed 25 percent under 4 feet. Average length, 4½ feet.

9. *Select*.—The face may contain sapwood and will admit pinworm holes, streaks, slight imperfections in working, or a small tight knot, not to exceed one to every 3 feet in length. Bundles shall be 2 feet and up in length. Average length, 4 feet.

10. *No. 1 Common*.—This grade shall be of such nature as to enable the laying of a sound floor without cutting. Bundles shall be 2 feet and up in length. Average length, 3 feet.

11. *No. 2 Common*.—This grade may contain defects of any character, but it shall be of such nature as to enable the laying of a serviceable floor. Bundles shall be 1¼ feet and up in length. Average length, 2½ feet.

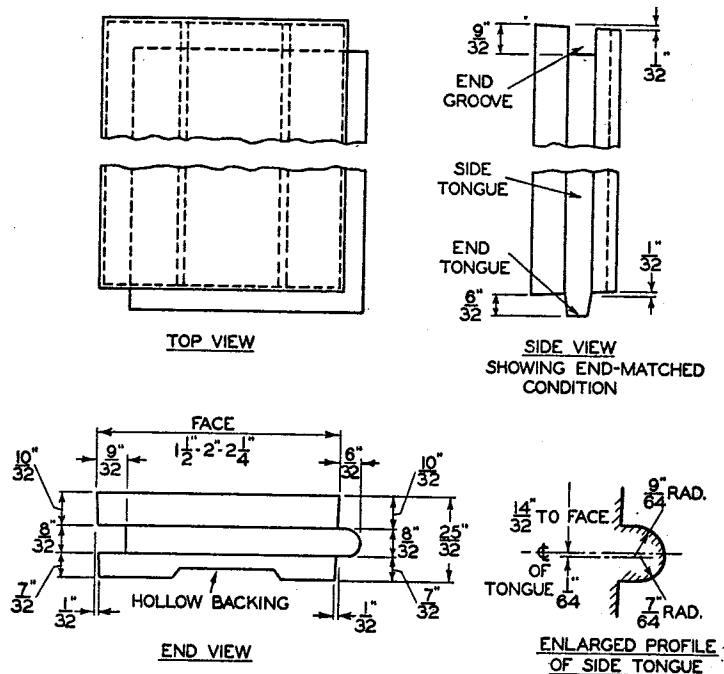

FIGURE 1. Dimensions for 2½-inch oak flooring.

Hollow backing. 2½-inch flooring with 1½-, 2-, and 2¼-inch faces shall have groove on back ⅜ inch deep ⅝, ¾, or 1 inch wide, respectively; with sides beveled 1/16 inch.

<sup>2</sup> See footnote 1.

<sup>3</sup> See footnote 1.

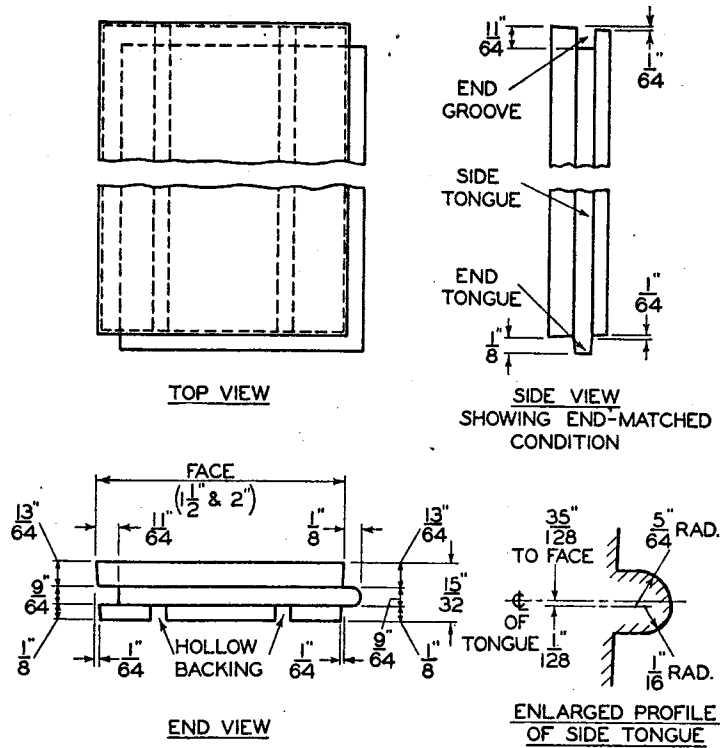

FIGURE 2.—Dimensions for 1 1/2-inch oak flooring.

Hollow backing. 1 1/2-inch flooring with 1 1/2- and 2-inch faces shall have two square grooves on back, each 1/8 inch deep, 1/64 inch wide, and spaced 1 inch center to center.

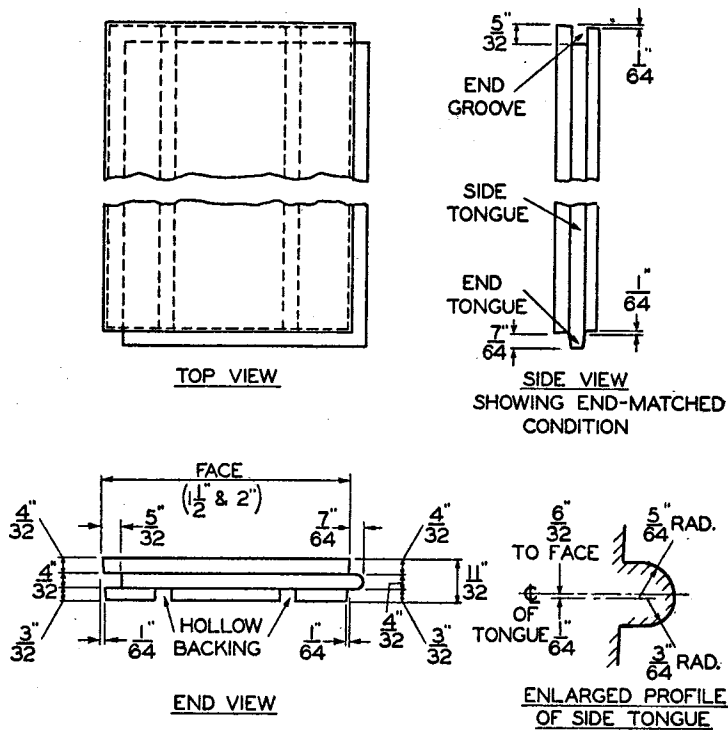

FIGURE 3. Dimensions for 1 1/2-inch oak flooring.

Hollow backing. 1 1/2-inch flooring with 1 1/2- and 2-inch faces shall have two square grooves on back, each 3/32 inch deep, 1/64 inch wide, and spaced 1 1/2 inch center to center.

## SQUARE-EDGED STRIP

12. Square-edged strip flooring is manufactured in "Clear," "Select," "No. 1 Common," and "No. 2 Common" grades. The grading requirements shall be the same as those for like grades of quarter-sawed and plain-sawed flooring, except that bundling and lengths shall be as follows:

*Clear.*—Bundles shall be 2 feet and up in length. Average length, 5½ feet.

*Select.*—Bundles shall be 2 feet and up in length. Average length, 4½ feet.

*No. 1 Common.*—Bundles shall be 2 feet and up in length. Average length, 3½ feet.

*No. 2 Common.*—Bundles shall be 1¼ feet and up in length. Average length, 2½ feet.

## STANDARD THICKNESSES AND WIDTHS

13. *Tongued, grooved, and end-matched.*—Standard thicknesses and face widths for tongued, grooved, and end-matched flooring are given in table 1.

TABLE 1.

Thickness (inch)	Face width (inches)
2½/32-----	1½; 2; 2¼; ¾
15/32-----	1½; 2.
11/32-----	1½; 2.

14. *Square-edged.*—Standard thickness and face widths for square-edged flooring are given in table 2. This type is also made with rough back in 1½/32-inch thickness, 1½- and 2-inch face.

TABLE 2.

Thickness (inch)	Face width (inches) 1
5/16-----	¾; 1; 1½; 1¼; 1½; 1½; 2.

<sup>1</sup> All faces are finished ¼ inch over face.

## BUNDLING

15. Oak flooring is bundled by averaging the lengths. A bundle may include pieces from 6 inches under to 6 inches over the nominal length of the bundle.

16. The percentages under 4 feet referred to in this standard apply to total footage (board feet) in any one shipment of the item.

## MEASUREMENT

17. *Thickness.*—In computing the footage of standard oak flooring, a thickness of 1 inch shall be used.

18. *Width.*—Tongued-and-grooved flooring 2½/32 inch thick is counted as ¾ inch wider than the actual face width, and flooring 15/32 inch and

$1\frac{1}{32}$  inch thick is counted as  $\frac{1}{2}$  inch wider than the actual face width. Square-edged strip flooring shall be measured as of the actual face width.

19. *Length.*—A  $\frac{1}{4}$ -inch allowance for end-matching shall be added to the face length when measuring the length of each piece of flooring.

### INSPECTION

20. Utmost care is exercised in the manufacture and inspection of oak flooring, and although the most capable grading experts are employed to assure constant uniformity of standard grades, it must be remembered that they are dealing with a product of nature in which there will occasionally appear marginal pieces on which the judgment of two equally competent inspectors might differ.

21. The purchaser may refuse any shipment in which the total footage of subgrade pieces is in excess of 5 percent of the grade in question, as determined by official reinspection.

### REINSPECTION

22. If the reinspection results in a difference in favor of the purchaser of more than 5 percent in feet (board measure), as shown on the invoice, then the shipper shall pay all the expenses of reinspection. If, on the other hand, the difference is only 5 percent or less in feet (board measure), the purchaser shall pay all the expenses of reinspection.

23. The quality and condition of oak flooring as it leaves the manufacturer is held to govern the reinspection.

### CERTIFICATION

24. In order to assure the purchaser that he is getting oak flooring of the grade specified, producers may individually, or in concert with their trade association or inspection bureau, issue a certificate of grade with each shipment, or grade- and trade-mark each piece or bundle as conforming to this established standard.

### MANUFACTURERS' RECOMMENDATIONS

25. The following information is not part of the commercial standard for oak flooring, but represents the custom of the trade and the manufacturers' recommendations, based on long experience, for maximum service from the use of oak flooring.

TABLE 3. *Standard counts and weights of oak flooring*

Actual size (inches)	Counted size (inches)	Weight per M ft (pounds)
$2\frac{5}{32}$ by $3\frac{1}{4}$ .....	1 by 4.....	2,250
$2\frac{5}{32}$ by $2\frac{1}{4}$ .....	1 by 3.....	2,000
$2\frac{5}{32}$ by 2.....	1 by $2\frac{3}{4}$ .....	2,000
$2\frac{5}{32}$ by $1\frac{1}{2}$ .....	1 by $2\frac{1}{4}$ .....	2,000
$1\frac{5}{32}$ by 2.....	1 by $2\frac{1}{2}$ .....	1,300
$1\frac{1}{32}$ by $1\frac{1}{2}$ .....	1 by 2.....	1,300
$1\frac{1}{32}$ by 2.....	1 by $2\frac{1}{2}$ .....	1,000
$1\frac{1}{32}$ by $1\frac{1}{2}$ .....	1 by 2.....	1,000
$\frac{5}{16}$ by 2.....	Face count.....	1,200
$\frac{5}{16}$ by $1\frac{1}{2}$ .....	do.....	1,200

## DETERMINATION OF QUANTITY REQUIRED

26. To determine the quantity required, ascertain the square footage of the area to be covered and add thereto the following amounts:

50 percent for.....	$2\frac{5}{32}$ by $1\frac{1}{2}$ in.
$37\frac{1}{2}$ percent for.....	$2\frac{3}{32}$ by 2 in.
$33\frac{1}{3}$ percent for.....	$2\frac{5}{32}$ by $2\frac{1}{4}$ in.
$33\frac{1}{3}$ percent for.....	$1\frac{5}{32}$ by $1\frac{1}{2}$ in.
25 percent for.....	$1\frac{7}{32}$ by 2 in.
$33\frac{1}{3}$ percent for.....	$1\frac{1}{32}$ by $1\frac{1}{2}$ in.
25 percent for.....	$1\frac{1}{32}$ by 2 in.

The above figures are based on laying flooring straight across the room. Where there are bay windows or other projections, allowance should be made for additional flooring. It is always well to order 5 percent additional flooring to take care of floor layers' cutting and possible damage if carelessly handled.

TABLE 4. Method of determining board-foot contents of a bundle of oak flooring

Number of pieces per bundle	Size (inches)	Multiply the length of bundle by—
12.....	$2\frac{5}{32}$ by $1\frac{1}{2}$ .....	$2\frac{1}{4}$
12.....	$2\frac{3}{32}$ by 2.....	$2\frac{3}{4}$
12.....	$2\frac{5}{32}$ by $2\frac{1}{4}$ .....	3
12.....	$2\frac{5}{32}$ by $3\frac{1}{4}$ .....	4
18.....	$1\frac{7}{32}$ by $1\frac{1}{2}$ .....	3
18.....	$1\frac{5}{32}$ by 2.....	$3\frac{3}{4}$
24.....	$1\frac{1}{32}$ by $1\frac{1}{2}$ .....	4
24.....	$1\frac{7}{32}$ by 2.....	5
30.....	$\frac{9}{16}$ by $1\frac{1}{2}$ .....	$3\frac{3}{4}$
30.....	$\frac{9}{16}$ by 2.....	5

## ESSENTIALS OF GOOD OAK-FLOOR CONSTRUCTION

27. It is vitally important that the following precautions be taken preliminary to the laying of oak flooring, to insure beautiful, enduring hardwood floors.

28. Defer delivery of the oak flooring until all plastering, cement, masonry work, painting, wallpapering, and interior finishing are completed and all are thoroughly dry. In no circumstances should the laying begin until such work is completed and the interior atmosphere is dry.

29. *Temporary heat.*—In winter weather, the building should have heat turned on before flooring is laid, to remove dampness existing in the cold atmosphere. In summer months, in certain parts of the country where there is excessive moisture, buildings of importance usually have some heat turned on before, during, and after the laying of the oak flooring, in order to remove excess moisture from the interior atmosphere. In such conditions it is best to have the bundles delivered inside the building about a week before starting to lay the flooring.

30. *Floor joists.*—Floor joists should be of thoroughly air- or kiln-dried lumber and spaced not more than 16 inches, center to center, for subfloor construction.

31. *Oak flooring laid on open joists.*—When there is no subfloor, oak flooring of  $2\frac{5}{32}$ -inch thickness is to be laid directly on the floor



joists, spaced 12 inches, center to center. Joists should be cross-bridged for added rigidity.

32. *Subfloor construction—underfloors.*—A subfloor is the foundation of the finished floor.

33. In new buildings, it is presumed there will be an underfloor, or subfloor, laid over the joists. A subfloor must be provided in all cases where the oak flooring is of less than  $2\frac{1}{2}$ -inch thickness. It is a permanent advantage to have oak floors laid over a subfloor.

34. Subflooring should be 1- by 4-inch or 1- by 6-inch stock, sized, No. 1 Common or No. 2 Common grade, of good, new, kiln-dried lumber, laid diagonally (at  $45^\circ$ ) to the joists. The boards should be driven close, but not tight.

35. The subfloor boards should be square-edged, not tongued and grooved or shiplapped, and not wider than 6 inches, and should be clean and straight. Avoid boards that have been used as forms for concrete work.

36. *Nailing the subfloors.*—Boards must be nailed down solid at every bearing with two 10-penny nails. All butt joints must rest on bearings. If it is absolutely necessary to use subfloor boards wider than 6 inches, extra nailing must be employed.

37. One of the secrets of obtaining a solid, nonsqueaking, almost "one-piece" oak floor, is to use plenty of nails in both the subfloor and the top floor. See nail schedule, table 5, page 9.

38. *Conditioning subfloor surface.*—Examine the subfloor carefully. Remove all dirt and plaster lumps, drive down any raised nails, replace broken boards, and make sure the floor is level and solid. Then sweep clean. Use no water.

39. *Building paper and insulation.*—Lay a good quality building paper over the clean subfloor. Use building paper of a type known as "15-lb asphalt-saturated roll felt." Do not use thin, black-sized or red rosin-sized paper, or slaters' felt.

40. *Insulating over heating plant.*—For rooms directly over heating plants, use double-weight building paper (30-lb asphalt felt) or 30-lb asbestos paper, or standard insulating board about  $\frac{1}{2}$  inch thick. If preferred, the insulation can be applied (in new or old buildings) on the basement ceiling, set in between the floor joists.

41. *Sleepers, or screeds.*—If the underfloor or subfloor is to be omitted and the oak flooring is to be nailed directly to wood "sleepers," or "screeds," set in or on the concrete slab, the sleepers should be spaced not more than 12 inches, center to center.

42. When a subfloor is to be installed over a concrete slab, the sleepers may then be spaced on 16- or 18-inch centers. Sleepers should be tightened in place. For this purpose there are various approved devices such as galvanized metal clips, expansion bolts in lead sleeves, and wire. Fastening and tightening by twisting strong wire around sleepers has proved a simple and effective method.

43. *Preserved lumber for sleepers.*—Sleepers should be of pretreated lumber, impregnated with an approved wood preservative. They should be of a lumber grade equivalent to No. 1 Common, 2 by 4 inches or 2 by 3 inches, and laid with the flat side down.

44. *Floor furring.*—When electrical conduits and piping are to be laid on top of the wood subfloor, floor furring strips of the required thickness, and  $1\frac{1}{4}$  inches wide, are spaced on 10-inch centers and tacked

to the subfloor. They are laid at right angles to the direction of the finished flooring. The flooring is nailed through the furring strips, nails one size larger than those specified in the nail schedule, table 5, page 9, being used.

45. *Floor ventilation.*—Where basements are not provided, adequate provision must be made for the free movement of cross currents of air beneath the building. This circulation may be obtained by providing vents and other openings in the foundation walls.

46. The total area of vent openings should be at least 1½ percent of the first-floor area, and more if possible.

47. Stagnant and humid air under a building will encourage stain and decay. The preventive is air circulation. When conditions do not permit adequate ventilation, the oak flooring should never be less than standard 2½-inch thickness. Architectural designs requiring "low-slung" floors may be modified slightly to permit the introduction of sufficient ventilation openings.

#### NAILS AND NAILING

48. Proper nails and correct nailing hold the flooring in place, make the floor rigid, and prevent squeaks. The nails should be started through the strip where the tongue leaves the shoulder, and driven inwardly at an angle of 45° to 50° to the floor. (See fig. 4.) Countersink all nails with a steel set or use a nail for setting. Do not attempt to do this with a hatchet or hammer, as this may cause bruises and scars that cannot be removed by scraping and sanding.

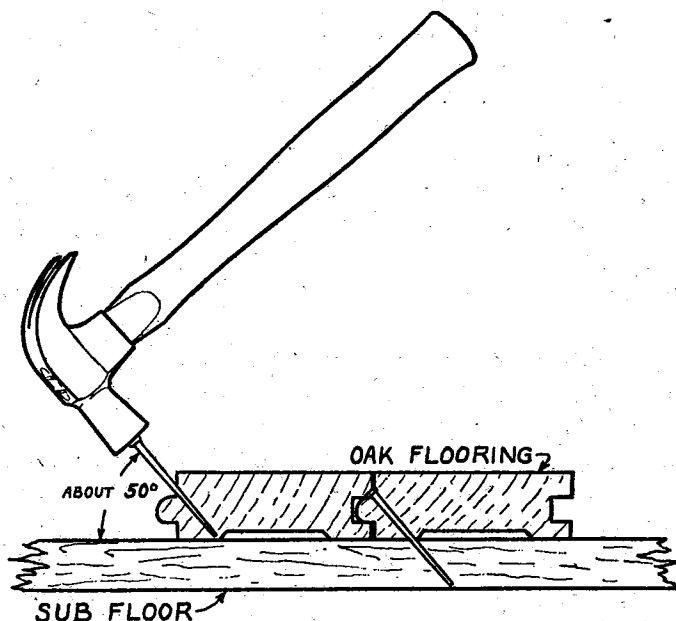

FIGURE 4. Method of nailing.

TABLE 5. Nail schedule

All tongued-and-grooved oak flooring must be blind-nailed.  
 All oak flooring  $\frac{1}{2}$  inch or less in thickness must be laid on a subfloor.  
 All square-edged flooring must be face-nailed (through the top face) instead of blind-nailed.

Flooring dimensions (inches)	Nails	
	Size	Spacing
$2\frac{5}{32}$ by 2, $2\frac{1}{2}$ , and $3\frac{1}{4}$ (tongued and grooved).	8d light flooring nail—wire or steel-cut casing nail (cut nail is preferable).	10 inches apart.
$2\frac{5}{32}$ by $1\frac{1}{2}$ (tongued and grooved).....	Same as above.....	12 inches apart.
$1\frac{9}{32}$ by $1\frac{1}{2}$ , and 2 (tongued and grooved).	6d bright wire casing nails.....	10 inches apart.
$1\frac{1}{32}$ by $1\frac{1}{2}$ , and 2 (tongued and grooved).	4d bright wire casing nails.....	8 inches apart.
$\frac{5}{16}$ by $1\frac{1}{2}$ , and 2 (square-edged).....	$1\frac{1}{8}$ inch barbed-wire flooring brad, No. 16; heads countersunk and put-tied.	2 nails every 7 inches.

## HOW TO LAY OAK FLOORING

49. The following instructions are intended for the laying of oak floors in new construction and over wood subfloors. However, they also apply generally to the laying of oak flooring over old floors.

50. *Where to begin.*—Leave an expansion space of not less than  $\frac{1}{2}$  inch on all sides next to the walls, but not wider than will be covered by the base-shoe, quarter-round, or door thresholds or saddles.

51. The flooring strips are to be started square with the room, against either sidewall. These first strips are to be face-nailed along the edges next to the wall where the base-shoe will conceal the nailing. All other flooring strips are blind-nailed on the tongued edge, except square-edged flooring.

52. *Drawing up.*—After laying and nailing three or four strips of oak flooring, place a short piece of straight-edged hardwood against the tongue of the outside strip of flooring, and drive it up snugly. This drives the flooring strips into their final position.

53. *Flush floor.*—Whenever possible, carry the laying through doorways continuously from one room into another, so that all rooms will have a flush floor. Avoid laying a ripped strip at doors or where it may mar the appearance.

54. *Joints.*—All pieces of flooring strips are tongued and grooved on the sides and on the ends. This is called "side and end matching." The fit of all pieces is practically perfect when laid side to side and end to end. The end jointing, therefore, may come anywhere in the floor, without regard to a joist or a sleeper bearing at the joint; but joints should be placed so as to avoid having two or three ends in line or clustered together.

55. *Random laying.*—Oak flooring of  $2\frac{5}{32}$  inch thickness is made in widths of  $1\frac{1}{2}$  and  $2\frac{1}{4}$  inches, and also  $3\frac{1}{4}$  inches when ordered. Specify the width desired, or call for all three widths—about an equal quantity of each—to be laid at random. This makes a very interesting floor with a mellowed effect, and is suited to all but the most formal styles of design.

56. *Laying new oak floors over old floors.*—The old floors serve as subfloors. Replace boards that cannot be planed or nailed down level, drive down all loose nails, nail the boards securely, and make

sure the old floor is level and free of humps. Remove the base-shoe, or molding strip, at the bottom of the base (baseboard). Sweep clean, and lay saturated felt. Then proceed with the laying of the new oak floor, laying it at right angles to the old floor.

57. *Surfacing (scraping or sanding)*.—Oak flooring is delivered to the job with a wearing surface that is beautifully smooth and as perfect as modern machinery can make it.

58. When ready for surfacing, the floor should be swept clean. Floors should be traversed several times, working on the first traverse across the grain and then lengthwise with the grain, starting with No. 2 sandpaper on the machine and graduating to No. 1/2 sandpaper, on the second traverse, and with No. 0 or No. 00 sandpaper on the third and fourth traverses. For very fine floors, four or five traverses are essential. The floor should then receive a final buffing or cleaning with fine sandpaper (No. 1/2 fine sandpaper that has been used on the machine sander) or No. 0 steel wool—by machine or by hand. Steel wool should not be used, however, just before or after a paste filler is applied.

59. After the floor has been sanded it should be swept perfectly clean, and no one permitted to walk on it until the floor stain, filler, or first coat of finish has been applied and is dry.

60. *Finishing*.—The finish of oak floors is of vital importance in achieving complete floor satisfaction. Modern floor finishes by many well-known producers are available. For complete information on floor finishes to suit individual tastes, the manufacturers of these products should be consulted.

#### EFFECTIVE DATE

61. Having been passed through the regular procedure of the Commodity Standards Division, and approved by the acceptors hereinafter listed, this commercial standard was issued by the United States Department of Commerce, effective from February 25, 1949.

EDWIN W. ELY,

Chief, Commodity Standards Division.

#### HISTORY OF PROJECT

On December 12, 1935, the National Oak Flooring Manufacturers' Association requested the cooperation of the Division of Trade Standards (now Commodity Standards Division) in bringing together all interested parties for the development and establishment of a commercial standard for oak flooring. Since members of the Association represented a large percentage of the production volume of oak flooring, the preliminary draft of the standard was based upon requirements contained in the Association's grading rules. The proposed standard was circulated to the trade for acceptance on December 14, 1935.

Upon receipt of official acceptances estimated to represent a satisfactory majority of the production volume, an announcement of promulgation of the standard was issued on February 14, 1936. Designated as CS56-36, the standard was made effective for new production from March 15, 1936.

## FIRST REVISION

In 1940 the supply of printed copies of this standard became exhausted and a revision of the standard was undertaken to bring it up to date. The major improvement consisted in listing the flooring by actual thicknesses instead of by nominal thicknesses. Upon approval by the standing committee, this revision was circulated on September 16, 1940, for acceptance. In view of the favorable response to this circularization from manufacturers, distributors, architects, and users, the success of the revision was announced on January 2, 1941. The revised standard, designated CS56-41, became effective February 1, 1941.

## SECOND REVISION

At the suggestion of the National Oak Flooring Manufacturers' Association, and with the endorsement of the standing committee, a recommended revision of Commercial Standard CS56-41 was submitted on September 30, 1948, to the trade for consideration. The major change effected by this revision was a slight reduction in the average lengths of the flooring, to permit a better utilization of the material now available. However, no change was made in the defects permitted in the various grades.

On January 26, 1949, it was announced that the recommended revision had been accepted by a sufficient number of manufacturers, distributors, and users to warrant its promulgation and publication as Commercial Standard CS56-49.

## STANDING COMMITTEE

The following individuals comprise the membership of the standing committee, which is to review, prior to circulation for acceptance, revisions proposed to keep the standard abreast of progress. Each organization nominated its own representative. Comment concerning the standard and suggestions for revision may be addressed to any member of the committee or to the Commodity Standards Division, National Bureau of Standards, which acts as secretary for the committee.

*Manufacturers:*

- B. A. MAYHEW (chairman), Fordyce Lumber Co., Fordyce, Ark.
- W. J. WRIGHT, M. B. Farrin Lumber Co., Winton Place Station, Cincinnati, Ohio.
- V. A. SELLS, Long-Bell Lumber Co., 926 Grand Ave., Kansas City, Mo.

*Distributors:*

- FRED A. HOLBROOK, Holbrook Lumber Co., Springfield, Mass. (Representing National-American Wholesale Lumber Association.)
- FRED R. STAIR, Farragut Lumber Co., Inc., 1350 No. Sixth Ave., Knoxville, Tenn. (Representing National Retail Lumber Dealers Association.)

*Users:*

- THEODORE I. COE, Department of Education and Research, American Institute of Architects, 1741 New York Ave., NW., Washington, D. C.
- C. O. CHRISTENSON, Property Requirements Section, Federal Housing Administration, Washington 25, D. C.

# ACCEPTANCE OF COMMERCIAL STANDARD

If acceptance has not previously been filed, this sheet properly filled in, signed, and returned will provide for the recording of your organization as an acceptor of this commercial standard.

Date-----

Commodity Standards Division,  
National Bureau of Standards,  
Washington 25, D. C.

Gentlemen:

We believe that the Commercial Standard CS56-49 constitutes a useful standard of practice, and we individually plan to utilize it as far as practicable in the

production<sup>1</sup>                      distribution<sup>1</sup>                      purchase<sup>1</sup>

of oak flooring. We reserve the right to depart from it as we deem advisable.

We understand, of course, that only those articles which actually comply with the standard in all respects can be identified or labeled as conforming thereto.

Signature of authorized officer-----  
(In ink)

(Kindly typewrite or print the following lines)

Name and title of above officer-----

Organization-----  
(Fill in exactly as it should be listed)

Street address-----

City, zone, and State-----

(Cut on this line)

<sup>1</sup> Underscore which one. Please see that separate acceptances are filed for all subsidiary companies and affiliates which should be listed separately as acceptors. In the case of related interests, trade associations, trade papers, etc., desiring to record their general support, the words "General Support" should be added after the signature.